

NOTE- PERFORMANCE AS PER ISO 9906 GRADE-2B

PERFORMANCE CURVE OF 10SW19 @1480 R.P.M

10SW19/X/602454



PUMPSENSE

SW RANGE

MODEL 10SW19

WORKING PRESS. 12 bar

SIZE 300x250-480

TEST PRESS. 18 bar

TYPE-DRY PIT NON-CLOG SEWAGE PUMP

SPHERE SIZE -100MM

SPEED 1480 rpm

SHADED REGION ON THE H-Q CURVE REPRESENTS OPTIMUM SELECTION ZONE

PUMP PERFORMANCE CHARACTERISTICS COMPUTED BASED ON CLEAN COLD WATER S.G 1.0

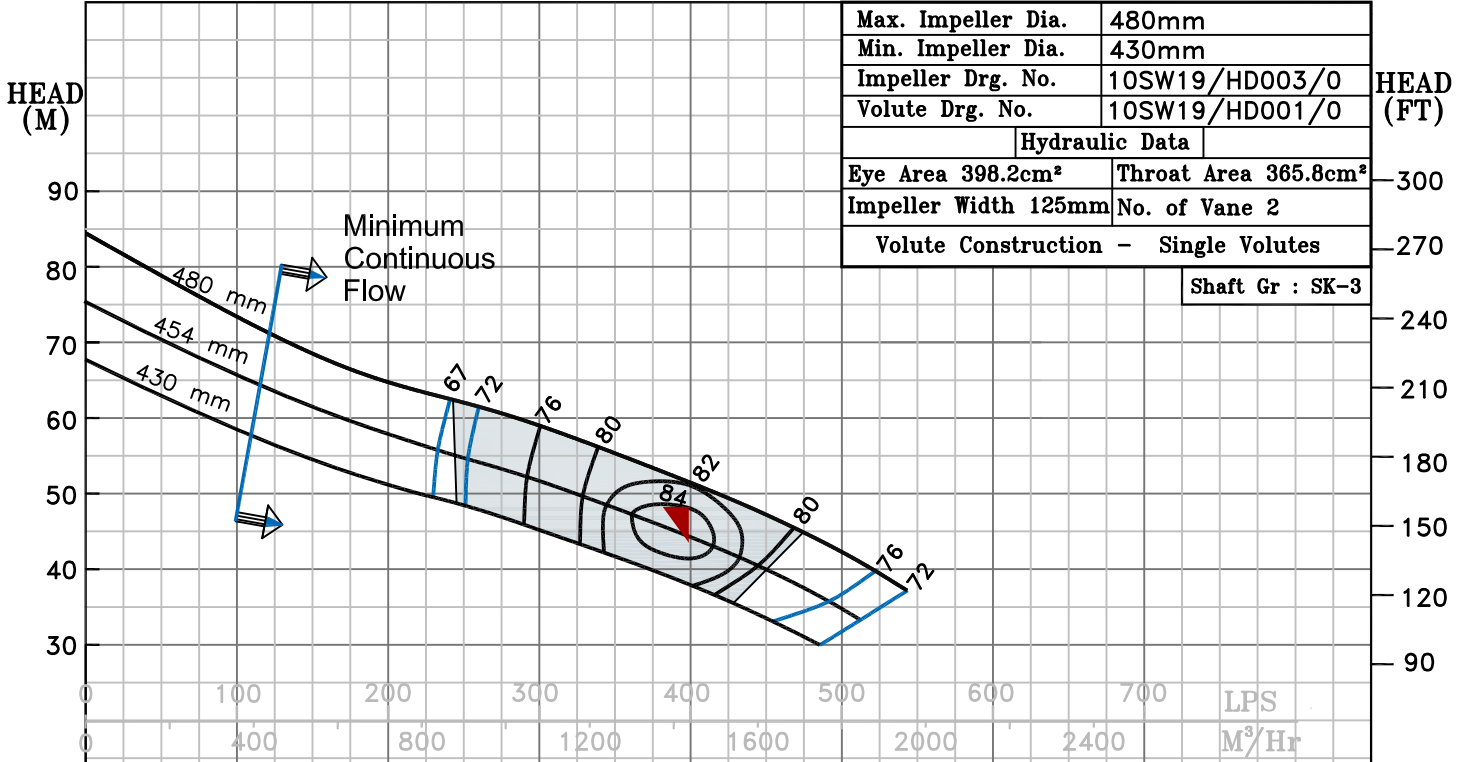

Max. Impeller Dia.	480mm
Min. Impeller Dia.	430mm
Impeller Drg. No.	10SW19/HD003/0
Volute Drg. No.	10SW19/HD001/0
Hydraulic Data	
Eye Area 398.2cm²	Throat Area 365.8cm²
Impeller Width 125mm	No. of Vane 2
Volute Construction - Single Volute	
Shaft Gr : SK-3	

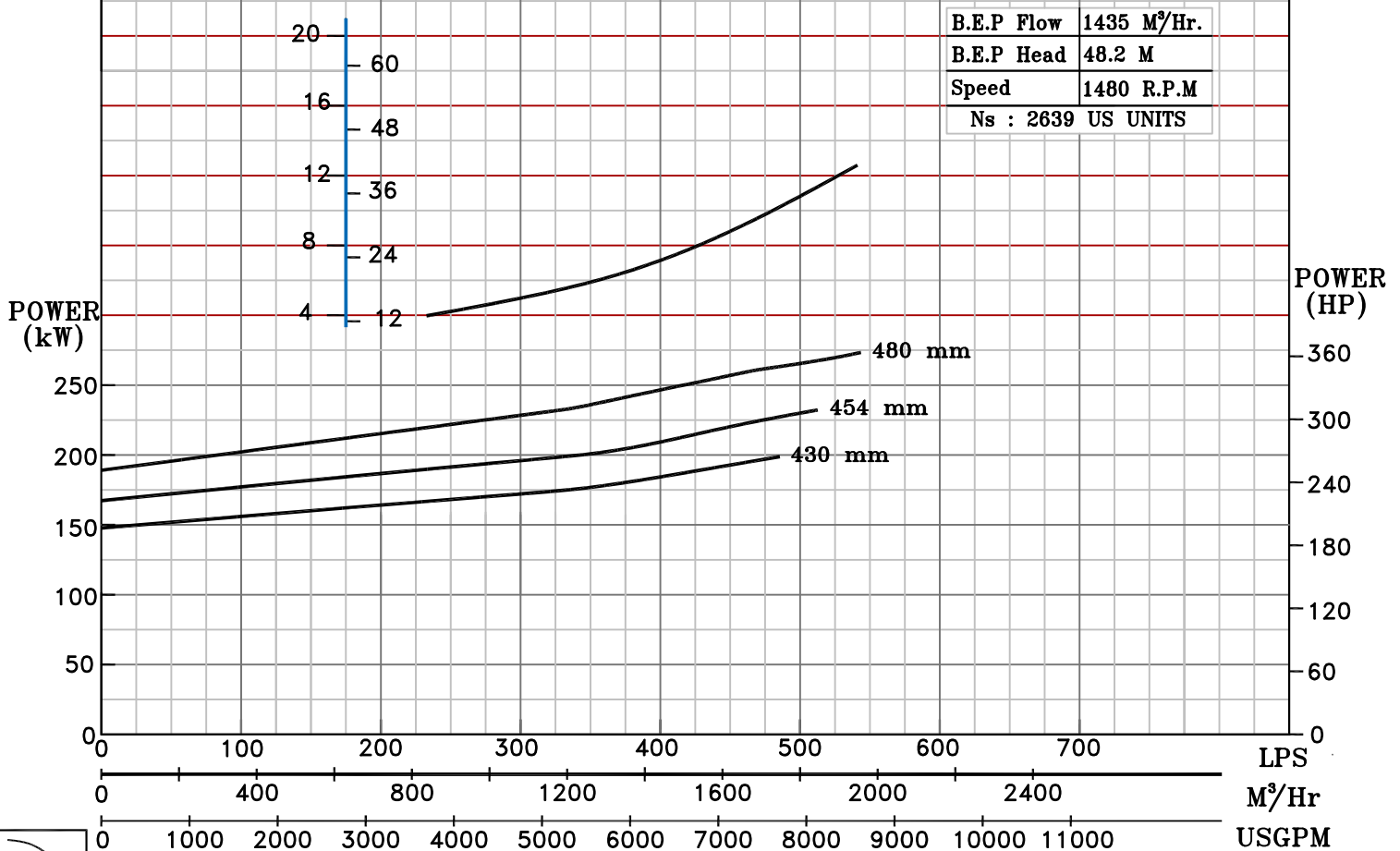

B.E.P Flow	1435 M³/Hr.
B.E.P Head	48.2 M
Speed	1480 R.P.M
Ns	: 2639 US UNITS



1480 RPM