

PERFORMANCE CURVE OF ESL 350-550 @980 R.P.M

ESL 350-550/X/0912



PUMPSENSE

ESL RANGE

MODEL	ESL 350-550	WORKING PRESS.	16 bar
SIZE	450x350-540	TEST PRESS.	24 bar
TYPE- END SUCTION		BACK PULL OUT	
SPEED 980 rpm			

SHADED REGION ON THE H-Q CURVE REPRESENTS OPTIMUM SELECTION ZONE

PUMP PERFORMANCE CHARACTERISTICS COMPUTED BASED ON CLEAN COLD WATER S.G 1.0

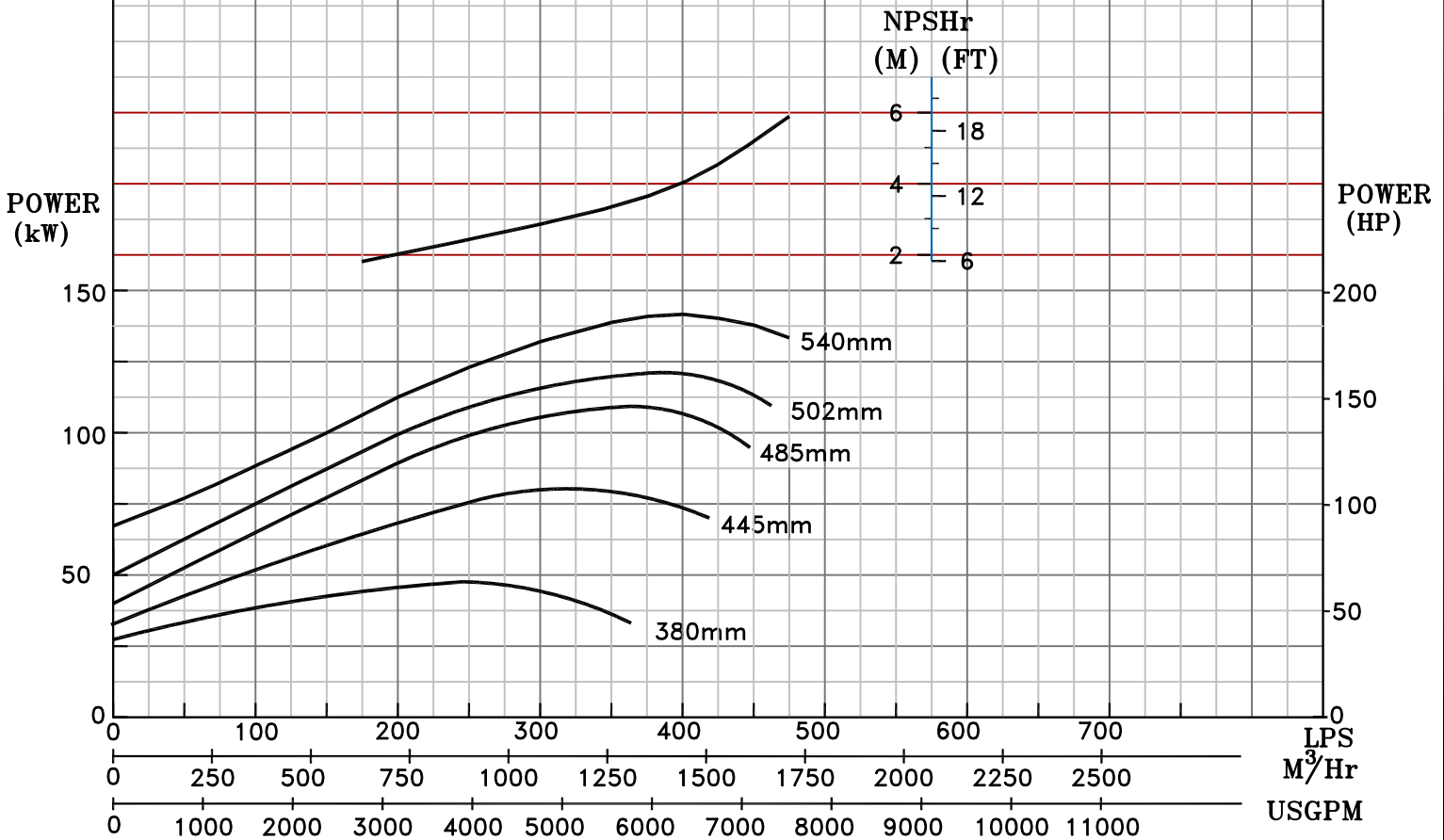
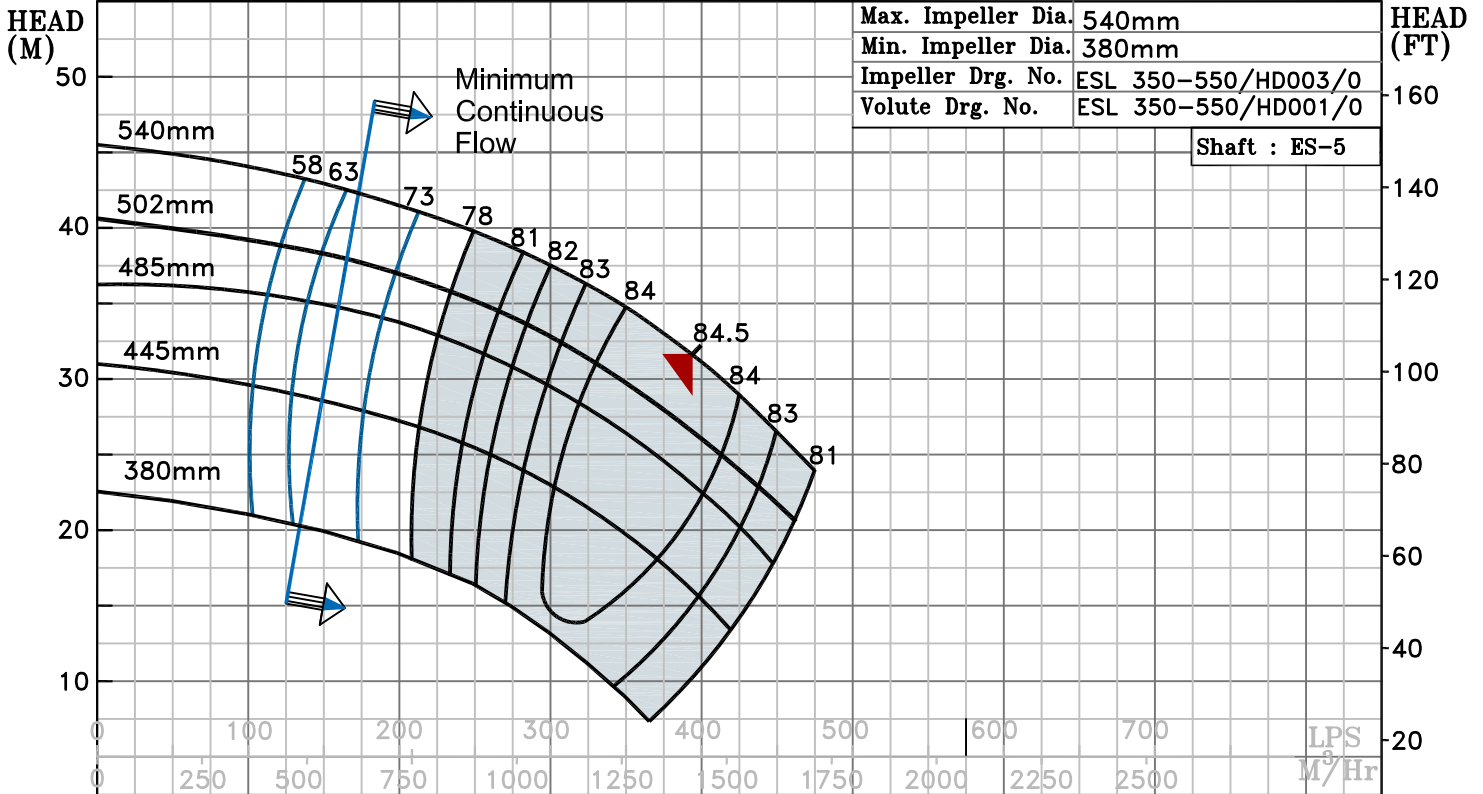

980 RPM